

@ info@thule.com

www.thule.com  
www.thuleprofessional.com

Thule Sweden AB, Box 69, 330 33 Hillerstorp, SWEDEN

**THULE**<sup>®</sup>  
SWEDEN

- GB** Fitting instructions
- D** Montageanleitung
- F** Instructions de montage
- NL** Montage-instructies
- I** Istruzioni per il montaggio
- E** Instrucciones de montaje
- PT** Instruções de Montagem
- S** Monteringsanvisning
- FIN** Asennusohje
- EST** Paigaldusjuhend
- LAT** Stiprināšanas instrukcija
- LIT** Pritvirtinimo instrukcijos
- PL** Instrukcja montażu
- RU** Инструкции по установке
- CZ** Návod na montáž
- SK** Návod na montáž
- SLO** Navodila za pritrjevanje
- HR** Uputa za sastavljanje
- HU** A felszerelés módja
- GR** Οδηγίες συναρμολόγησης
- TR** Montaj talimatları
- 中文 安装说明
- 日本語 取扱(取付)説明書
- 한국어 장착 지침
- ไทย คำแนะนำการติดตั้ง

**CITROËN Dispatch**, 4/5-dr Van, 07-

**CITROËN Jumpy**, 4/5-dr Van, 07-

**FIAT Scudo**, 4/5-dr Van, 07-

**PEUGEOT Expert**, 4/5-dr Van, 07-

**RAPID  
FIXPOINT XT**

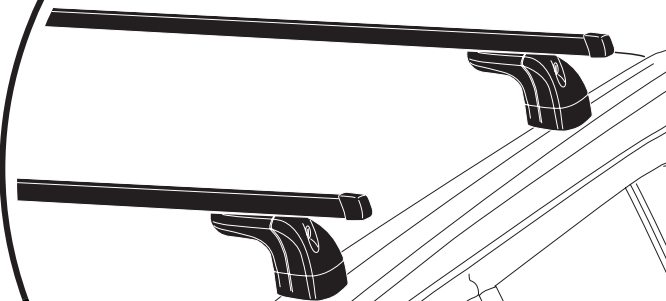

**3051**  
133051



**Follow me...**

804•4DF/8/501-3051-02

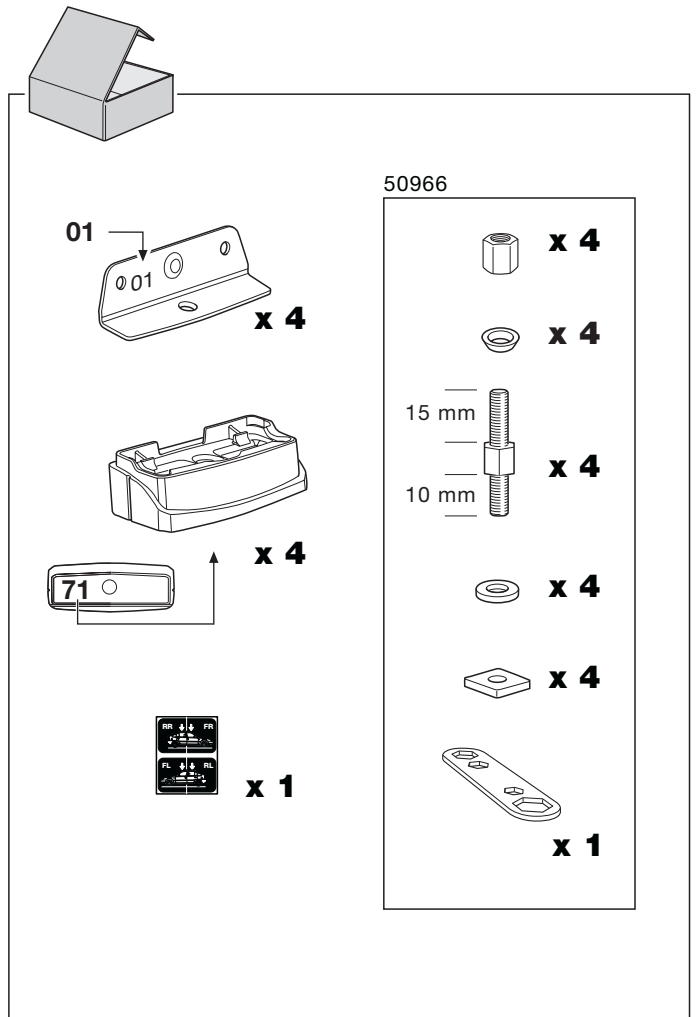
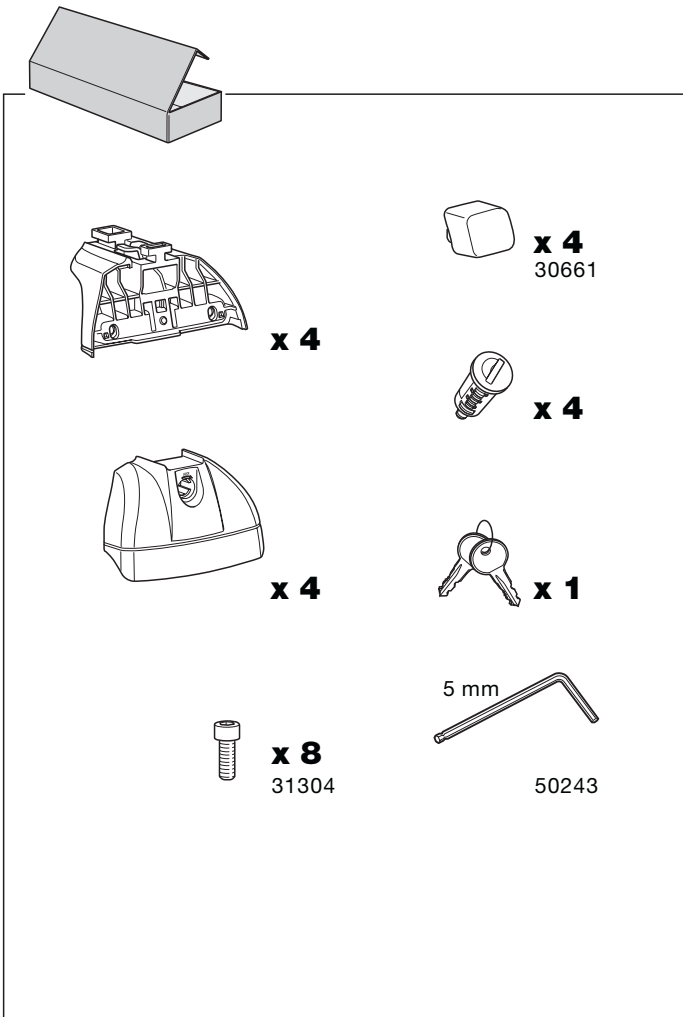
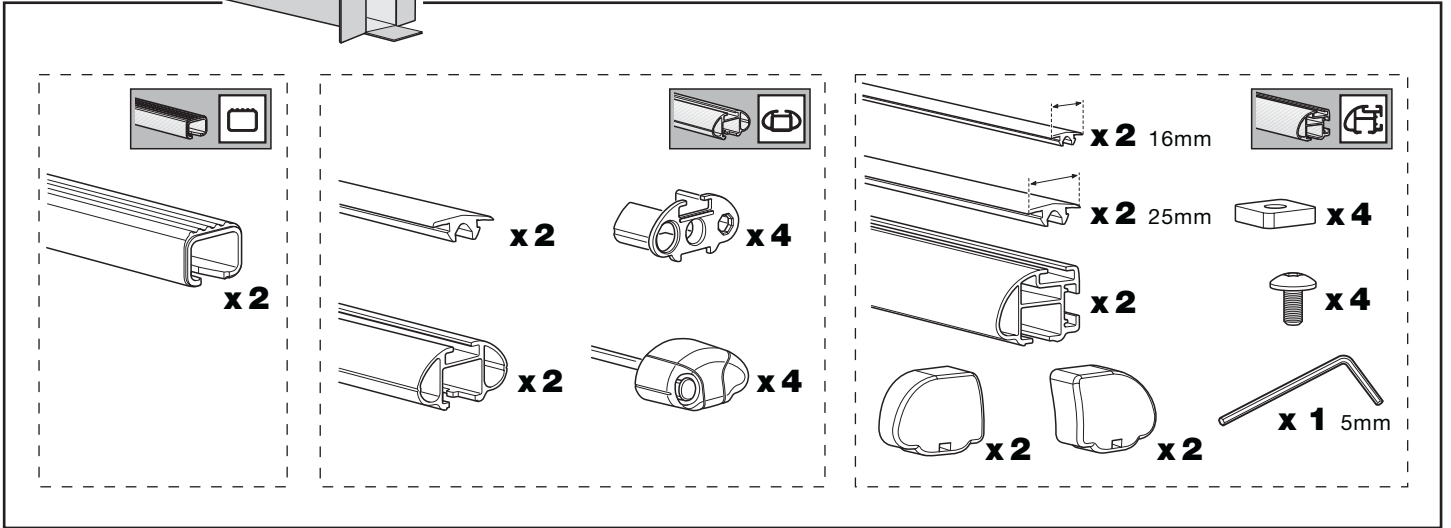
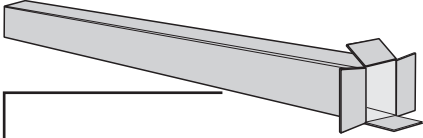
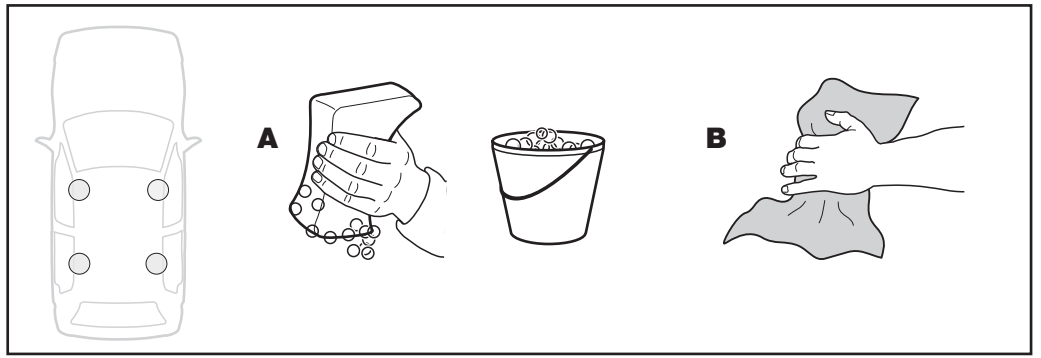
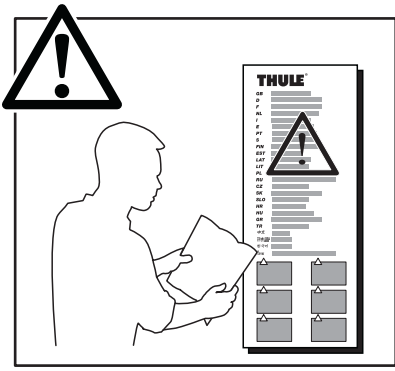

1



x 4



x 4

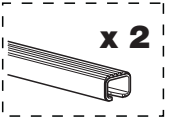

x 2

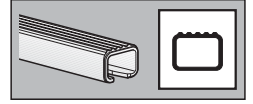
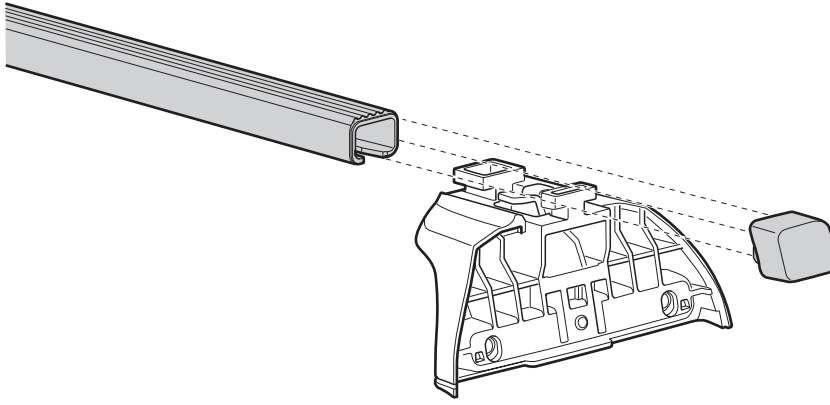

x 4

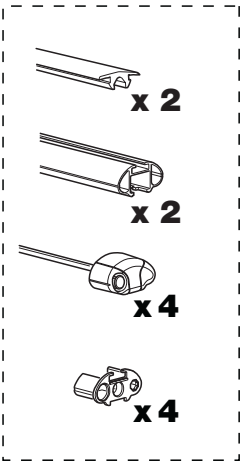

x 2

x 2

x 4

x 4

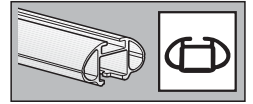
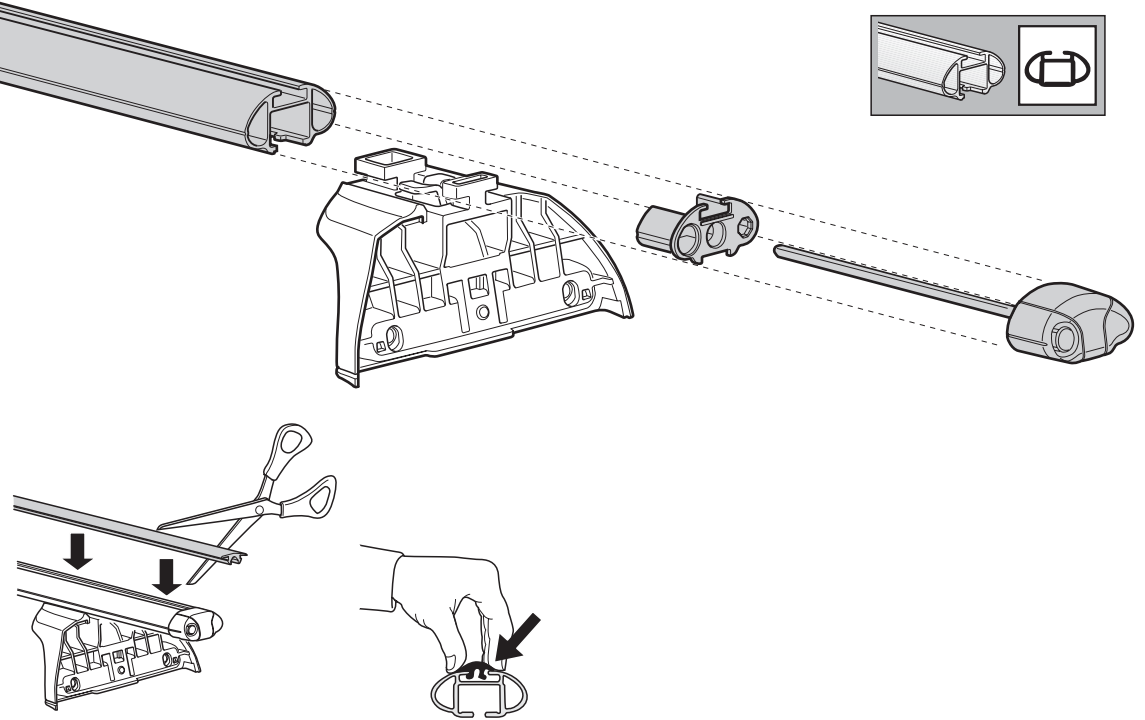

x 4

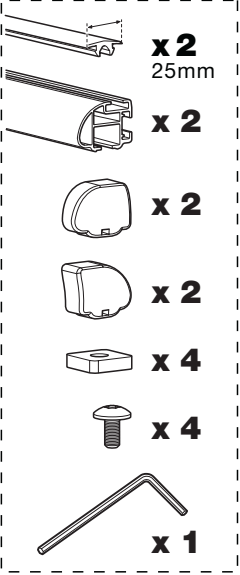

x 2

25mm

x 2

x 2

x 2

x 4

x 4

x 1

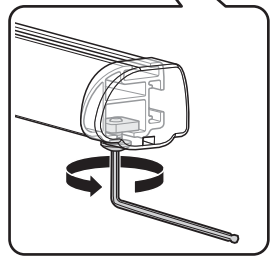
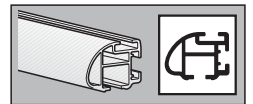
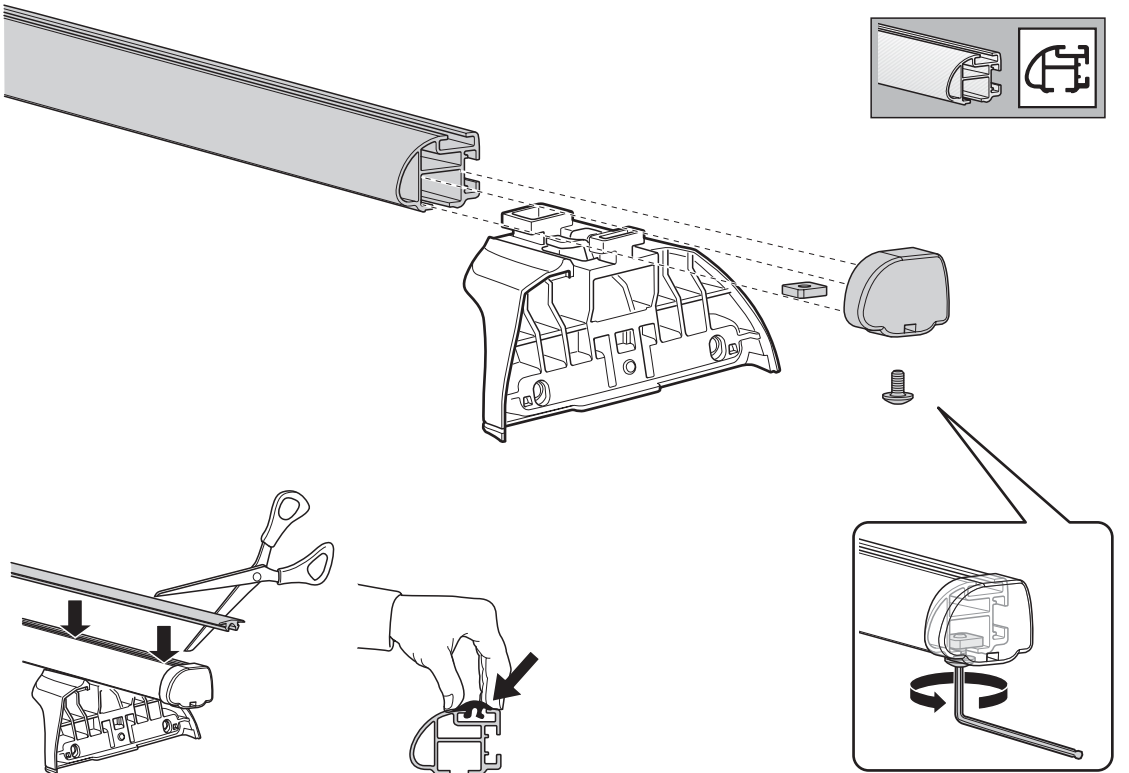

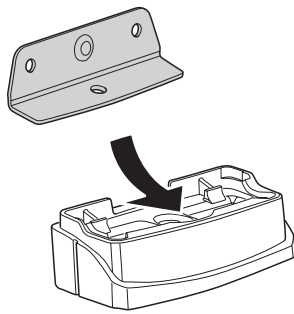
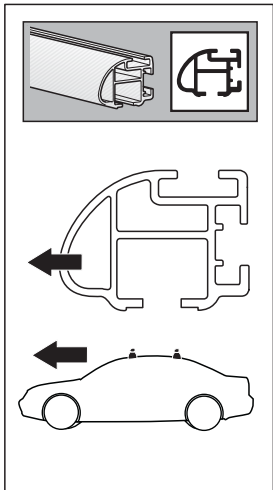
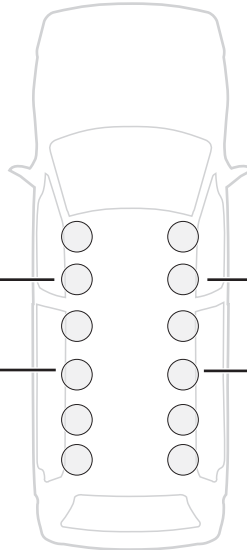
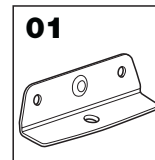
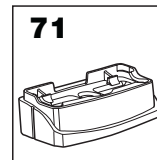
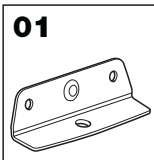
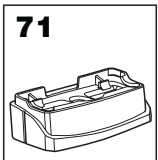
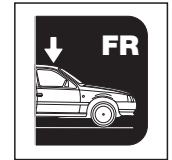
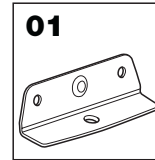
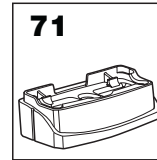
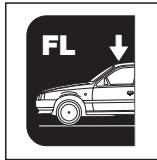
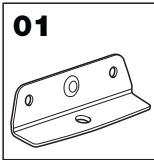
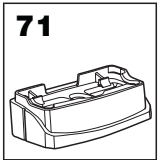
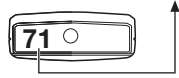
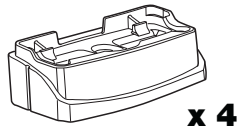
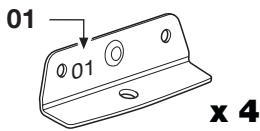



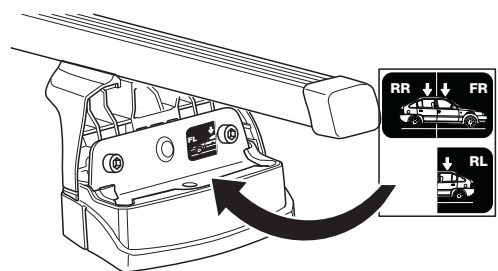
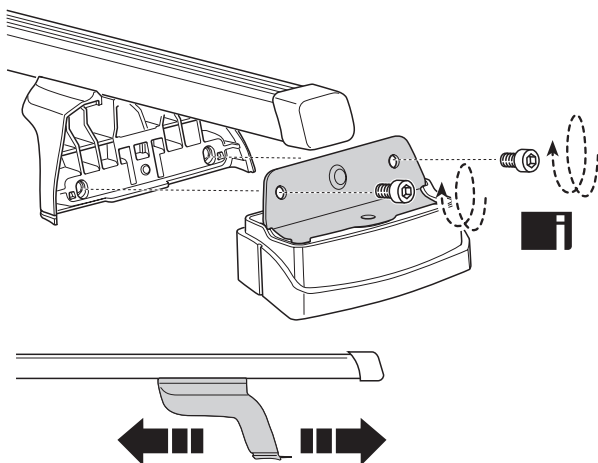

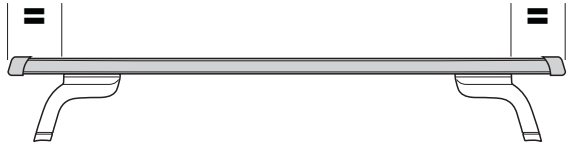

- |            |                           |            |                                |
|------------|---------------------------|------------|--------------------------------|
| <b>GB</b>  | Only a few turns          | <b>RU</b>  | Достаточно нескольких оборотов |
| <b>D</b>   | Nur wenige Umdrehungen    | <b>CZ</b>  | Pouze několik otáčok           |
| <b>F</b>   | Quelques tours uniquement | <b>SK</b>  | Len niekoľko otáčok            |
| <b>NL</b>  | Slechts enkele slagen     | <b>SLO</b> | Le nekaj obratov               |
| <b>I</b>   | Solo qualche giro         | <b>HR</b>  | Samo nekoliko okreta           |
| <b>E</b>   | Sólo algunas vueltas      | <b>HU</b>  | Csak néhány fordítás           |
| <b>PT</b>  | Noções básicas            | <b>GR</b>  | Μόνο μερικές στροφές           |
| <b>S</b>   | Endast några varv         | <b>TR</b>  | Yalnız birkaç kez çevirme      |
| <b>FIN</b> | Vain muutama kierros      | <b>中文</b>  | 只有几个转向                         |
| <b>EST</b> | Ainult mõni pööre         | <b>한국어</b> | 두 세번만                          |
| <b>LAT</b> | Tikai dažī apgriezieni    | <b>日本語</b> | 数回転のみ                          |
| <b>LIT</b> | Tik keli pasukimai        | <b>ไทย</b> | หมุนเพียงไม่กี่รอบ             |
| <b>PL</b>  | Wystarczy kilka obrotów   |            |                                |



3

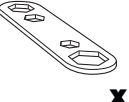

-  x 4
-  x 4
-  x 4
-  x 4
-  x 4
-  x 1
-  x 1

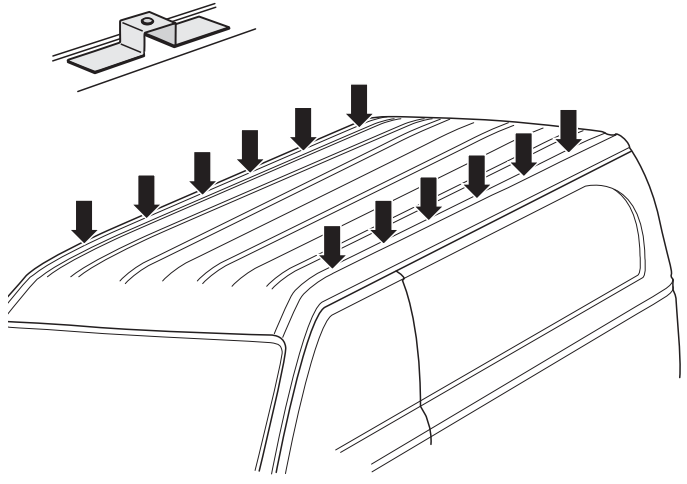

A

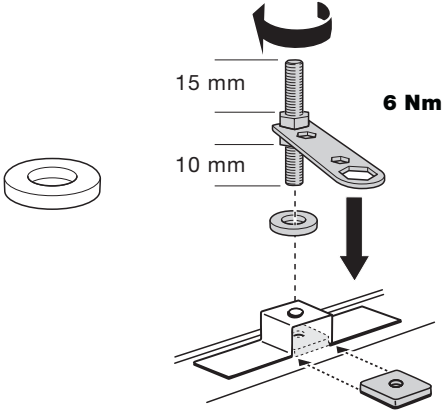

B

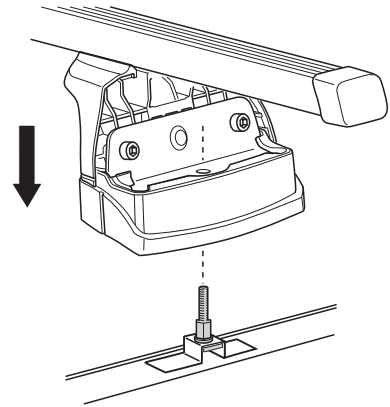

C

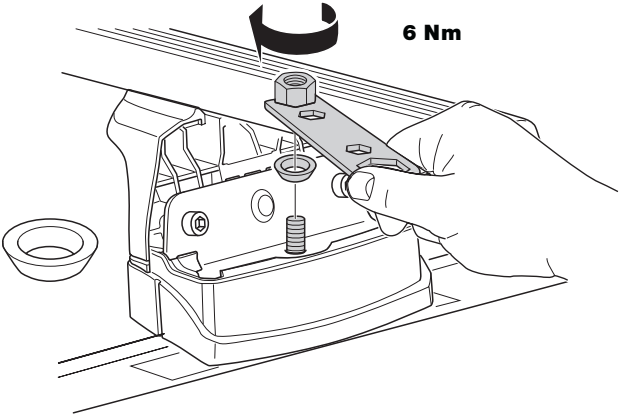

D

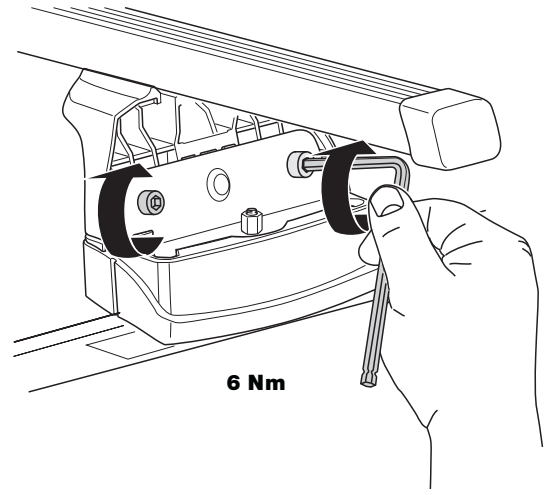

**4**



**x 4**



**x 4**



**x 1**

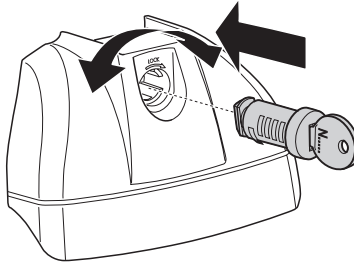

**5**

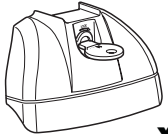

**x 4**

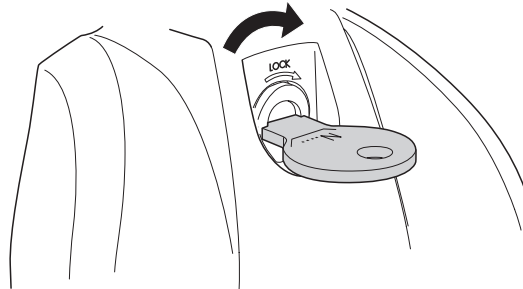
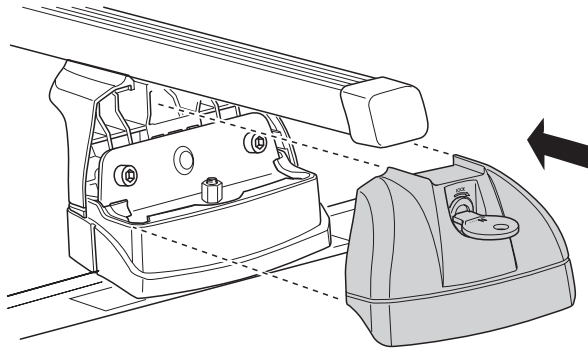

**6**

