

FITTING INSTRUCTION

Clamp mark in acc. with		Cables joining
ISO	PN	
1	L	Left directional lights
2	+	Rear fog lights
3	31	Ground
4	R	Right directional lights
5	58R	Right side parking lights
6	54	Stoplights
7	58L	Left side parking lights

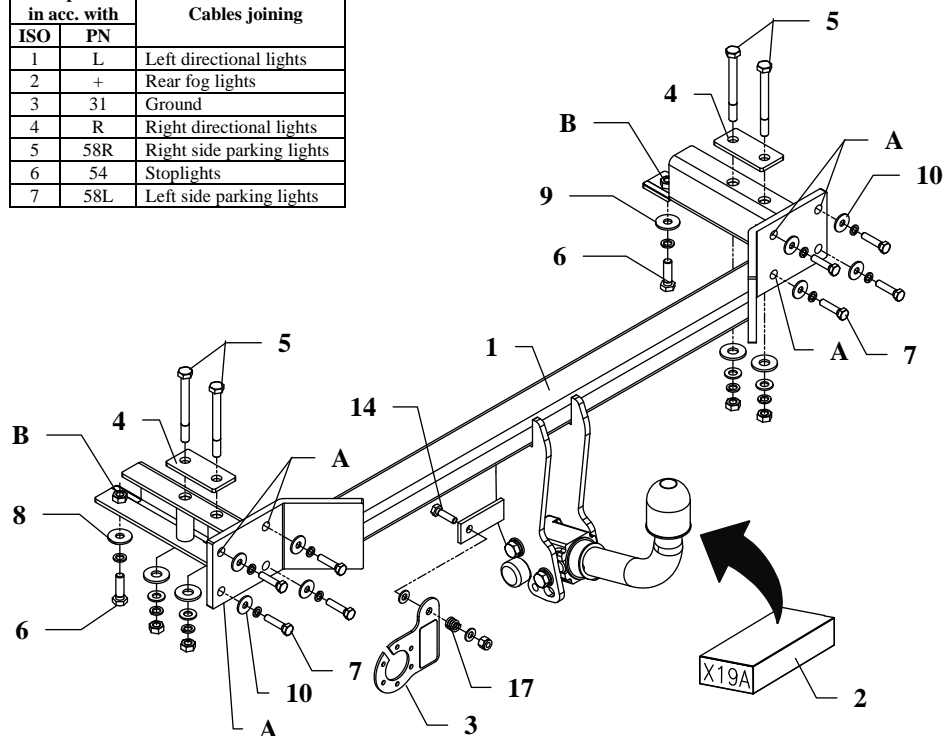

This towing hitch is designed to assembly in following cars:
CHEVROLET LACETTI, 4 doors, produced since 2005, catalogue no. **X19A** and is prepared to tow trailers max total weight **1200 kg** and max vertical load **75 kg**.

From manufacturer

Thank you for buying our product. Their reliability has been confirmed in many tests. Reliability of towing hitch depends also on correct assembly and correct exploitation. For this reasons we kindly ask to read carefully this instruction and apply to hints.

The towing hitch should be install in points described by a car producer.

The instruction of the assembly

1. Disassemble a rear bumper.
2. Unscrew reinforcement of the bumper, next unscrew fastening handles.
3. Reinforcement fix to the main bar of the towing hitch (pos. 1) in points A using bolts M8x35mm (pos. 7), use washers $\varnothing 24 \times 8,4 \times 2$ mm (pos. 10).
4. Apply the towing hitch with reinforcement to chassis members and fix from top using bolts M10x100mm (pos. 5) with fish-plate (pos. 4) and from the bottom through holes B using bolts M10x35mm (pos. 6), use washers $\varnothing 30 \times 10 \times 3$ mm (pos. 8) – see figure.
5. Fix body of the automat and place tow-ball (pos. 2) according to supplied instruction.
6. Fix the socket plate (pos. 3) as shown on the drawing.
7. Tighten all bolts according to the torque shown in the table.
8. Connect electric wires of 7-poles socket according to the instruction of the car. (Recommend to make at authorized service station)
9. Complete paint layer damaged during installation.

Torque settings for nuts and bolts (8,8):

M 8	25 Nm	M 10	55 Nm
M 12	85 Nm	M 14	135 Nm











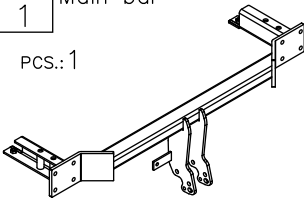

NOTE

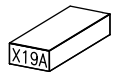
After install the towing hitch you should get adequate note in registration book (at authorised service station).The car should be equipped with:

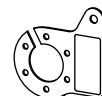
- Indicators
- Tow mirrors

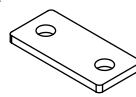
After 1000km check all bolts and nuts. The ball of towing hitch must be always kept clear and conserve with a grease.

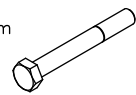
Towing hitch accessories:

Pos. 1 Main bar  PCS.: 1	Pos. 6 Bolt 8,8 B M10x35mm  PCS.: 2	Pos. 12 Spring washer ø8mm  PCS.: 8
	Pos. 7 Bolt 8,8 B M8x35mm  PCS.: 8	Pos. 13 Nut 8 B M10  PCS.: 4
Pos. 2 Tow ball  PCS.: 1	Pos. 8 Washer ø30xø10,5x2,5mm  PCS.: 6	Pos. 14 Bolt 8,8 B M8x30mm  PCS.: 1
Pos. 3 Socket plate  PCS.: 1	Pos. 9 Plain washer ø10mm  PCS.: 4	Pos. 15 Plain washer ø8mm  PCS.: 2
Pos. 4 Fish-plate  PCS.: 2	Pos. 10 Washer ø24xø8,4x2mm  PCS.: 8	Pos. 16 Nut 8 B M8  PCS.: 1
Pos. 5 Bolt 8,8 B M10x100mm  PCS.: 4	Pos. 11 Spring washer ø10mm  PCS.: 6	Pos. 17 Spring  PCS.: 1



PPUH AUTO-HAK S.J.

Produkcja Haków Holowniczych
Henryk & Zbigniew Nejman
76-200 SŁUPSK ul. Słoneczna 16K
tel/fax (059) 8-414-414; 8-414-413
E-mail: office@autohak.com.pl
www. autohak.com.pl

Towing hitch (without electrical set)

Class: **A50-X** Cat. no. **X19A**

Designed for:

Manufacturer: **CHEVROLET**

Model: **LACETTI**

Type: **4 doors**

produced since 2005

Technical data:

D-value: 6,83 kg

maximum trailer weight: **1200 kg**

maximum vertical cup load: **75 kg**

Approval number acc. to regulations EKG/ONZ 55.01: E20-55R-01 1806

Foreword

This towing hitch is designed according to rules of safety traffic regulations. The towing hitch is a safety component and can be install only by qualified personnel. Any alteration or conversion of the towing hitch is prohibited and would lead to cancellation of design certification. Remove insulating compound and underseal from vehicle (if present) in the area of the matting surfaces of the towing hitch.

The vehicle manufacturer's specifications regarding trailer load and max. vertical cup load are decisive for driving, and values for the towing hitch cannot be exceeded.

D-value formula:

$$\frac{\text{Max trailer weight [kg]} \times \text{Max vehicle weight [kg]}}{\text{Max trailer weight [kg]} + \text{Max vehicle weight [kg]}} \times \frac{9,81}{1000} = D \text{ [kN]}$$