

FITTING INSTRUCTION

Clamp mark in acc. with		Cables joining
ISO	PN	
1	L	Left directional lights
2	+	Rear fog lights
3	31	Ground
4	R	Right directional lights
5	58R	Right side parking lights
6	54	Stoplights
7	58L	Left side parking lights

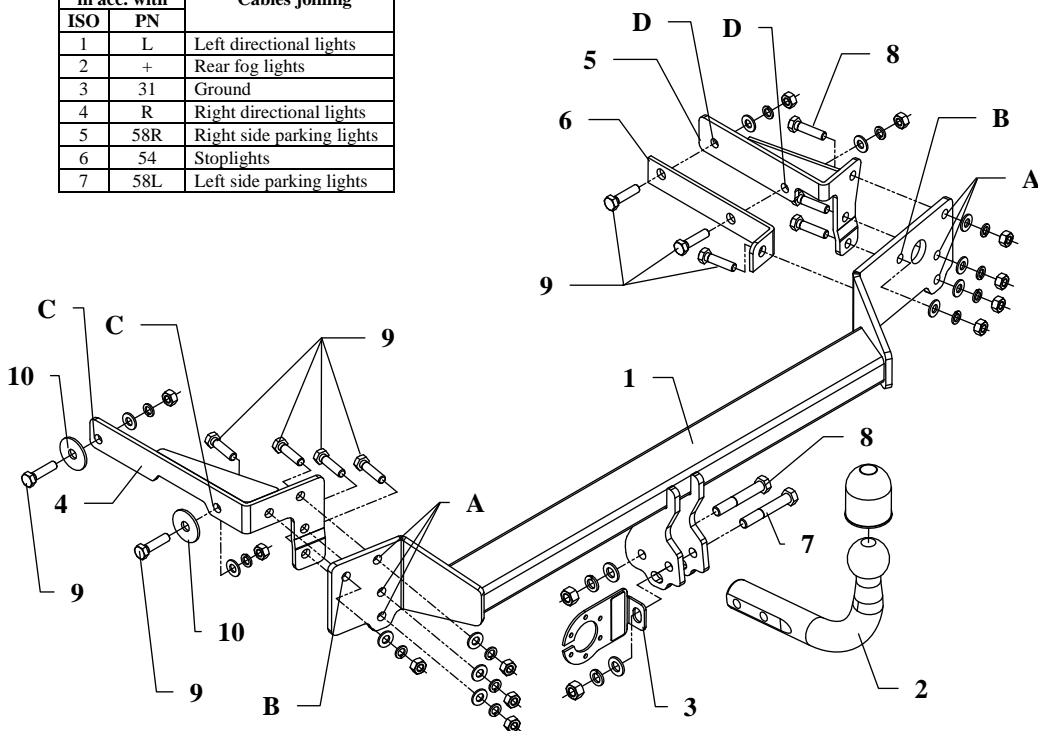

This towbar is designed to assembly in following car:
RENAULT CLIO B and C, 3/5 doors, produced since 03.1998 till 09.2005 and **CLIO CAMPUS 3/5 doors**, produced since 2005 till 2010, catalogue no. **G29** and is prepared to tow trailers max total weight **1200 kg** and max vertical mass **75 kg**.

From manufacturer

Thank you for buying our product. Their reliability has been confirmed in many tests. Reliability of towbar depends also on correct assembly and right operation. For this reasons we kindly ask to read carefully this instruction and apply to hints.

The towbar should be install in points described by a car producer.

The instruction of the assembly

1. Disassemble the bumper
2. Position the elements (pos. 5 and 6) to the right chassis member (find original holes)
 - position the element (pos. 5) to the right side
 - position the element (pos. 6) to the left side
3. Fix left bracket (pos. 4) to the left chassis member (find original holes), and then fix it through the holes (pos. C) using bolts M10x40mm (pos. 9).
4. Put main bar of the towbar (pos. 1) to the rear panel and fix it through the original holes and holes (pos. A and B) using bolts M10x40mm (pos. 9).
5. Reassemble the bumper.
6. Fix tow-ball (pos. 2) with socket plate (pos. 3) using bolts M12x75mm (pos. 7) and M12x70 (pos. 8) from accessories.
7. Tighten all bolts according to the torque shown in the table.
8. Connect electric wires of 7-poles socket according to the instruction of the car. (Recommend to make at authorized service station).
9. Complete paint layer damaged during installation.

Torque settings for nuts and bolts (8,8):

M6 - 11 Nm	M8 - 25 Nm	M10 - 50 Nm
M12 - 87 Nm	M14 - 138 Nm	M16 - 210 Nm







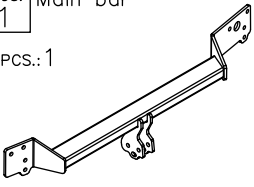
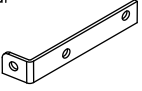
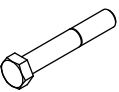

NOTE

After install the towbar you should get adequate note in registration book (at authorised service station).The car should be equipped with:

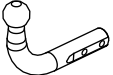
- Indicators
- Tow mirrors

After 1000km of exploitation check all bolts and nuts. The ball of towbar must be always kept clear and conserve with a grease.

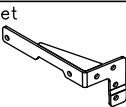
Towbar accessories:

Pos. 1 Main bar PCS.: 1	Pos. 6 Angle bar PCS.: 1	Pos. 12 Plain washer ø10,5mm PCS.: 12
	Pos. 7 Bolt 8,8 B M12x75mm PCS.: 1	Pos. 13 Spring washer ø12,2mm PCS.: 2
	Pos. 8 Bolt 8,8 B M12x70mm PCS.: 1	Pos. 14 Spring washer ø10,2mm PCS.: 12
	Pos. 9 Bolt 8,8 B M10x40mm PCS.: 12	Pos. 15 Nut 8 B M12 PCS.: 2
Pos. 2 Tow ball PCS.: 1		Pos. 16 Nut 8 B M10 PCS.: 12
	Pos. 10 Plain washer ø30xø10,5x2,5mm PCS.: 2	Pos. 17 Ball cover PCS.: 1
Pos. 3 Socket plate PCS.: 1		
	Pos. 11 Plain washer ø13mm PCS.: 2	
Pos. 4 Left bracket PCS.: 1		
		
Pos. 5 Right bracket PCS.: 1		
		



PPUH AUTO-HAK S.J.

Produkcja Zaczepów Kulowych
Henryk & Zbigniew Nejman
76-200 SŁUPSK ul. Słoneczna 16K
tel/fax (059) 8-414-414; 8-414-413
E-mail: office@autohak.com.pl
www.autohak.com.pl

Towing hitch (without electrical set)

Class: **A50-X** Cat. no. **G29**

Designed for:

Manufacturer: **RENAULT**

Model: **CLIO B and C**

Type: **3/5 doors**

produced since 03.1998 till 06.2001

and since 07.2001 till 09.2005 and

Model: **CLIO CAMPUS**

Type: **3/5 doors**

produced since 2005 till 2010

Technical data:

D-value: 6,55kN

maximum trailer weight: **1200 kg**

maximum vertical cup mass: **75 kg**

Approval number acc. to regulations EKG/ONZ 55.01: E20-55R-01 0971

Foreword

This towbar is designed according to rules of safety traffic regulations. The towing hitch is a safety component and can be install only by qualified personnel. Any alteration or conversion of the towing hitch is prohibited and would lead to cancellation of design certification. Remove insulating compound and underseal from vehicle (if present) in the area of the matting surfaces of the towing hitch.

The vehicle manufacturer's specifications regarding trailer load and max. vertical cup load are decisive for driving whereat values for the towing hitch cannot be exceeded.

D-value formula:

$$\frac{\text{Max trailer weight [kg]} \times \text{Max vehicle weight [kg]}}{\text{Max trailer weight [kg]} + \text{Max vehicle weight [kg]}} \times \frac{9,81}{1000} = D \text{ [kN]}$$